

Practice - Conservation of Energy

Name: _____

Date: _____

1. A 75-kilogram boy initially at rest skis down the slope as shown. Assuming no frictional loss, what will be his kinetic energy at the bottom of the slope?

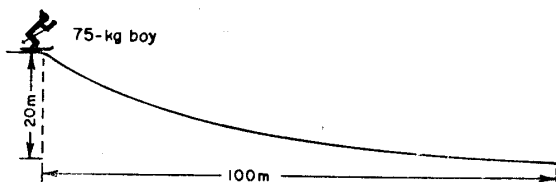

- A. 1,500 joules B. 7,500 joules
 C. 15,000 joules D. 75,000 joules
2. As a falling apple approaches the ground, its potential energy
- A. decreases B. increases
 C. remains the same
3. An object 10 meters above the ground has Z joules of potential energy. If the object falls freely, how many joules of kinetic energy will it have gained when it is 5 meters above the ground?
- A. Z B. $2Z$ C. $\frac{Z}{2}$ D. 0
4. A 1.0-kilogram mass gains kinetic energy as it falls freely from rest a vertical distance, d . How far would a 2.0-kilogram mass have to fall freely from rest to gain the same amount of kinetic energy?
- A. d B. $2d$ C. $\frac{d}{2}$ D. $\frac{d}{4}$
5. The sum of the kinetic and potential energies of an object's molecules is called the object's
- A. temperature B. heat of fusion
 C. internal energy D. specific heat

6. The diagram shows a cart at four positions as it moves along its track. At which positions is the *sum* of the potential energy and kinetic energy of the cart the same?

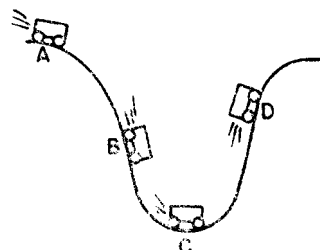

- A. A and B, only
 B. B and C, only
 C. C and D, only
 D. all positions, A through D
7. The diagram here shows a 1-kilogram stone being dropped from a bridge 100 meters above a gorge.

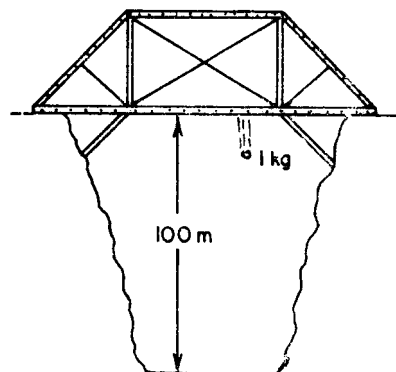

As the stone falls, the gravitational potential energy of the stone

- A. decreases B. increases
 C. remains the same

8. Each of the blocks in the diagrams is lifted vertically for the distance indicated. Which block will gain the most gravitational potential energy?

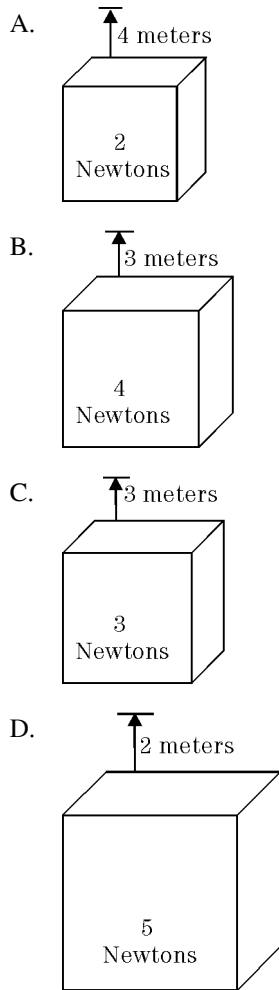

9. A basketball player who weighs 600 newtons jumps 0.5 meter vertically off the floor. What is her kinetic energy just before hitting the floor?

A. 30J B. 60J C. 300J D. 600J

10. A 0.10-kilogram ball dropped vertically from a height of 1.0 meter above the floor bounces back to a height of 0.80 meter. The mechanical energy lost by the ball as it bounces is approximately

A. 0.080J B. 0.20J
C. 0.30J D. 0.78J

11. As the pendulum swings from position *A* to position *B* as shown in the diagram, what is the relationship of kinetic energy to potential energy? [Neglect friction.]

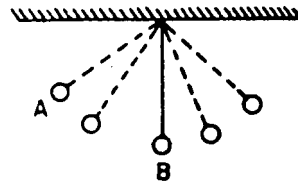

- A. The kinetic energy decrease is more than the potential energy increase.
B. The kinetic energy increase is more than the potential energy decrease.
C. The kinetic energy decrease is equal to the potential energy increase.
D. The kinetic energy increase is equal to the potential energy decrease.

12. Three people of equal mass climb a mountain using paths *A*, *B*, and *C* shown in the diagram. Along which path(s) does a person gain the greatest amount of gravitational potential energy from start to finish?

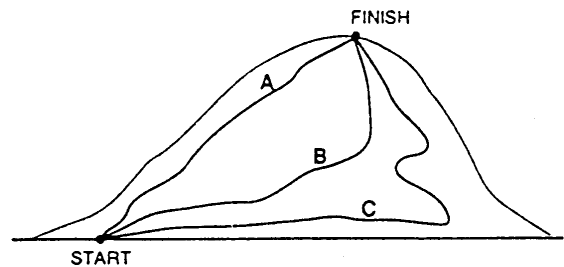

- A. *A*, only
B. *B*, only
C. *C*, only
D. The gain is the same along all paths.

13. As an object falls freely near the Earth's surface, the loss in gravitational potential energy of the object is equal to its

- A. loss of height
- B. loss of mass
- C. gain in velocity
- D. gain in kinetic energy

14. The diagram shown represents a frictionless track. A 10-kilogram block starts from rest at point A and slides along the track.

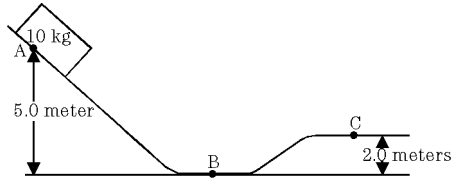

As the block moves from point A to point B, the total amount of gravitational potential energy changed to kinetic energy is approximately

- A. 5J B. 20J C. 50J D. 500J
15. What is the approximate potential energy of the block at point C?
- A. 20J B. 200J C. 300J D. 500J
16. A cart of mass M on a frictionless track starts from rest at the top of a hill having height h_1 , as shown in the diagram.

What is the kinetic energy of the cart when it reaches the top of the next hill, having height h_2 ?

- A. Mgh_1
- B. $Mg(h_1 - h_2)$
- C. $Mg(h_2 - h_3)$
- D. 0

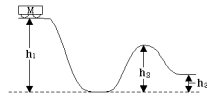

17. The accompanying diagram shows a moving, 5.00-kilogram cart at the foot of a hill 10.0 meters high. For the cart to reach the top of the hill, what is the minimum kinetic energy of the cart in the position shown? [Neglect energy loss due to friction.]

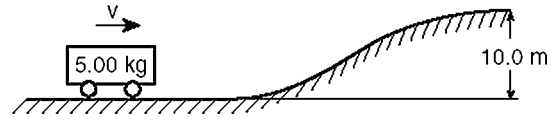

- A. 4.91 J B. 50.0J C. 250.J D. 491 J
18. Base your answer(s) to the following question(s) on the information and diagram below.

A 250.-kilogram car is initially at rest at point A on a roller coaster track. The car carries a 75-kilogram passenger and is 20. meters above the ground at point A. [Neglect friction.]

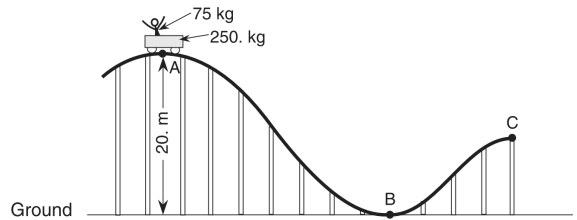

Compare the total mechanical energy of the car and passenger at points A, B, and C.

19. The diagram below shows an ideal simple pendulum.

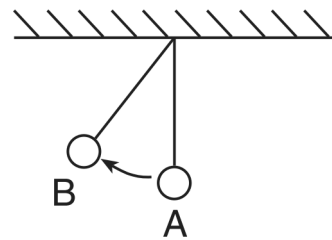

As the pendulum swings from position A to position B, what happens to its total mechanical energy? [Neglect friction.]

- A. It decreases.
- B. It increases.
- C. It remains the same.

20. An object falls freely near Earth's surface. Which graph best represents the relationship between the object's kinetic energy and its time of fall?

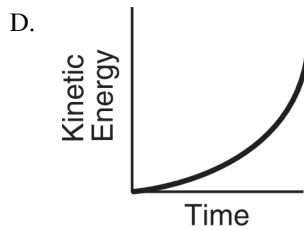
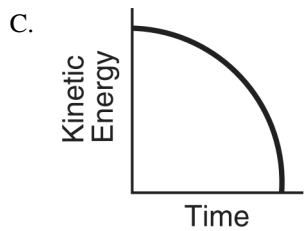
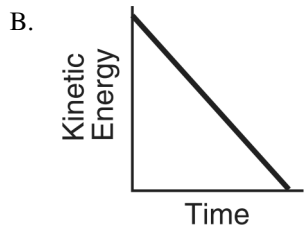
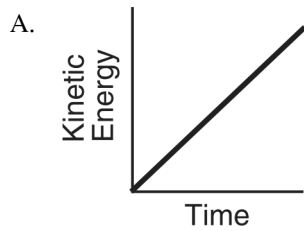

21. Which statement describes the kinetic energy and total mechanical energy of a block as it is pulled at constant speed up an incline?
- Kinetic energy decreases and total mechanical energy increases.
 - Kinetic energy decreases and total mechanical energy remains the same.
 - Kinetic energy remains the same and total mechanical energy increases.
 - Kinetic energy remains the same and total mechanical energy remains the same.

22. A wooden crate is pushed at constant speed across a level wooden floor. Which graph best represents the relationship between the total mechanical energy of the crate and the duration of time the crate is pushed?

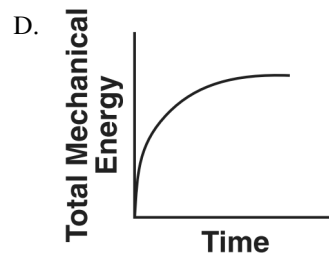
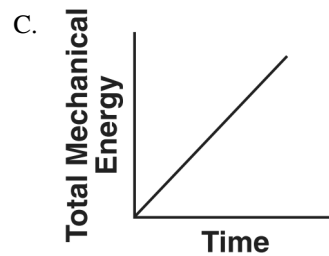
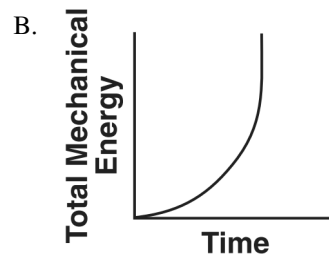
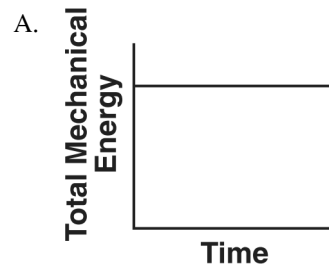

23. A book sliding across a horizontal tabletop slows until it comes to rest. Describe what change, if any, occurs in the book's kinetic energy and internal energy as it slows.

24. A 6.0-kilogram concrete block is dropped from the top of a tall building. The block has fallen a distance of 55 meters and has a speed of 30 meters per second when it hits the ground.

A. At the instant the block was released, what was its gravitational potential energy with respect to the ground? [Show all calculations, including the equation and substitution with units.]

B. Calculate the kinetic energy of the block at the point of impact. [Show all calculations, including the equation and substitution with units.]

C. How much mechanical energy was "lost" by the block as it fell?

D. Using one or more complete sentences, explain what happened to the mechanical energy that was "lost" by the block.

25. Base your answer(s) to the following question(s) on the information below.

A 65-kilogram pole vaulter wishes to vault to a height of 5.5 meters.

Calculate the *minimum* amount of kinetic energy the vaulter needs to reach this height if air friction is neglected and all the vaulting energy is derived from kinetic energy. [Show all work, including the equation and substitution with units.]

26. Calculate the speed the vaulter must attain to have the necessary kinetic energy. [Show all work, including the equation and substitution with units.]

27. Base your answer(s) to the following question(s) on the information and diagram below.

A 30.4-newton force is used to slide a 40.0-newton crate a distance of 6.00 meters at constant speed along an incline to a vertical height of 3.00 meters.

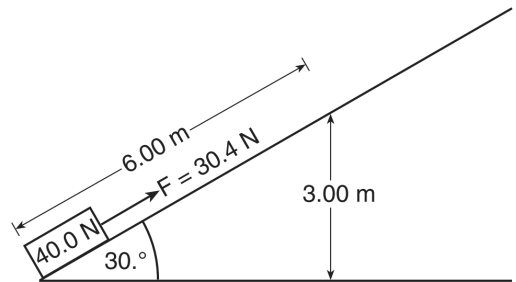

Calculate the total increase in the gravitational potential energy of the crate after it has slid 6.00 meters along the incline.

28. State what happens to the kinetic energy of the crate as it slides along the incline.

29. State what happens to the internal energy of the crate as it slides along the incline.

30. A student makes a simple pendulum by attaching a mass to the free end of a 1.50-meter length of string suspended from the ceiling of her physics classroom. She pulls the mass up to her chin and releases it from rest, allowing the pendulum to swing in its curved path. Her classmates are surprised that the mass doesn't reach her chin on the return swing, even though she does not move. Explain why the mass does not have enough energy to return to its starting position and hit the girl on the chin.

Practice - Conservation of Energy 2/8/2018

- | | |
|---|--|
| <p>1.
Answer: C</p> <p>2.
Answer: A</p> <p>3.
Answer: C</p> <p>4.
Answer: C</p> <p>5.
Answer: C</p> <p>6.
Answer: D</p> <p>7.
Answer: A</p> <p>8.
Answer: B</p> <p>9.
Answer: C</p> <p>10.
Answer: B</p> <p>11.
Answer: D</p> <p>12.
Answer: D</p> <p>13.
Answer: D</p> <p>14.
Answer: D</p> <p>15.
Answer: B</p> <p>16.
Answer: B</p> <p>17.
Answer: D</p> <p>18.
Answer: Total mechanical energy is the same at all three points.</p> <p>19.
Answer: C</p> | <p>20.
Answer: D</p> <p>21.
Answer: C</p> <p>22.
Answer: A</p> <p>23.
Answer: kinetic energy decreases
internal energy increases.</p> <p>24.
Answer: $\Delta PE = 3200 \text{ J}$</p> <p>25.
Answer: $KE = \Delta PE = mg\Delta h$
$KE = (65 \text{ kg})(9.81 \text{ m/s}^2)(5.5 \text{ m})$
$KE = 3.5 \times 10^3 \text{ J}$</p> <p>26.
Answer: $KE = \frac{1}{2}mv^2$
$v = \sqrt{\frac{2KE}{m}}$
$v = \sqrt{\frac{2(3.5 \times 10^3 \text{ J})}{65 \text{ kg}}}$
$v = 10. \text{ m/s}$</p> <p>27.
Answer: $\Delta PE = 120. \text{ J}$</p> <p>28.
Answer: The kinetic energy of the crate is constant.</p> <p>29.
Answer: The internal energy of the crate increases.</p> <p>30.
Answer: Acceptable responses include, but are not limited to: - friction - Some of the gravitational energy of the mass was converted into internal energy. Therefore, it could not return to its original height. - air resistance</p> |
|---|--|